

# J-355W-C

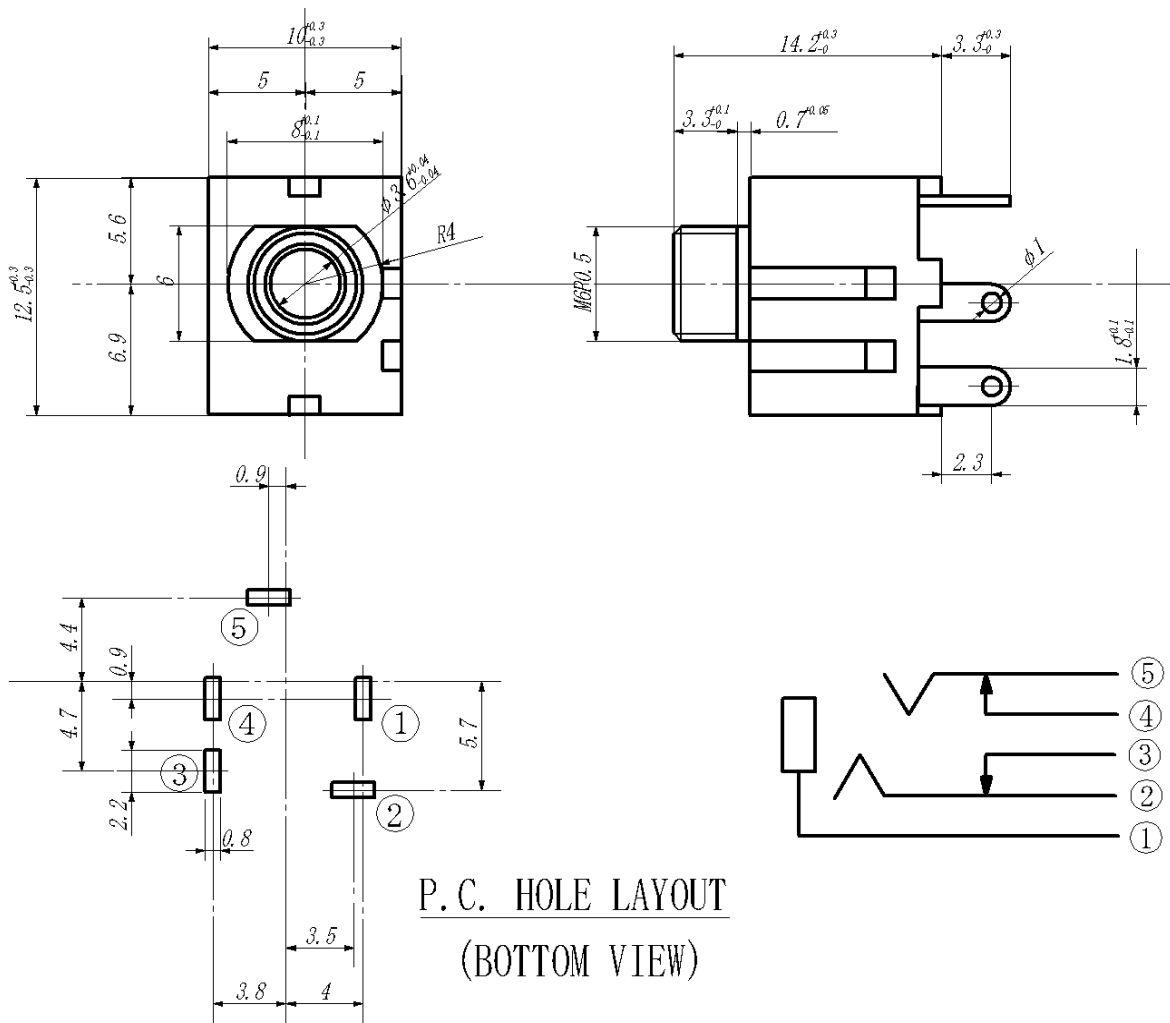

P. C. HOLE LAYOUT  
(BOTTOM VIEW)

	PART NAME	QTY	MATERIAL	FINISH	REMARKS
1	BODY	1	P. C. +G15%		BLACK
2	METAL	1	BsBM 6PHI	Ni-3	
3	SLEEVE CONTACT	1	BsR-1/2H 0.3t	Ag over Ni	
4	RING CONTACT	1	BsR-H 0.25t	Ag over Ni	
5	TIP CONTACT	1	BsR-H 0.25t	Ag over Ni	
6	SWITCH LEAD FOR TIP C.	1	BsR-1/2H 0.3t	Ag over Ni	
7	SWITCH LEAD FOR RING C.	1	BsR-1/2H 0.3t	Ag over Ni	
8	SPRING COIL FOR TIP C.	1	SUS-304	HEAT TREATMENT	
9	SPRING COIL FOR RING C.	1	SUS-304	HEAT TREATMENT	



Phone 1-800-809-2751

Fax 1-510-440-0579

www.connect-tech-products.com • info@connect-tech-products.com

4428 Technology Drive • Fremont, CA 94538, USA • 510-498-8815 • Fax: 510-440-0579